



PRODUCT SPECIFICATIONS

For Customer: _____ : APPROVAL FOR SPECIFICATION

Customer Model No. _____ : APPROVAL FOR SAMPLE

Module No.: ZW-T043QPH-71

Date : 2016-03-10

Table of Contents

No.	Item	Page
1	Cover Sheet(Table of Contents)	
2	Revision Record	
3	General Specifications	
4	Outline Drawing	
5	Absolute Maximum Ratings	
6	Electrical Specifications and Instruction Code	
7	Optical Characteristics	
8	Reliability Test Items and Criteria	
9	Packing Reliability	

For Customer's Acceptance:

Approved By	Comment

PREPARED	CHECKED	VERIFIED BY QA DEPT	VERIFIED BY R&D DEPT

2. Revision Record

Date	Rev.No.	Page	Revision Items	Prepared
2016-02-22	V0		The first release	ZHP
2016-03-10	V1		Add the interface timing and LCD Panel Grade	ZHP

3. General Specifications

ZW-T043QPH-71 is a TFT-LCD module. It is composed of a TFT-LCD panel, driver IC, FPC, a back light unit. The 4.3" display area contains 480 x 272 pixels and can display up to 16.7M colors. This product accords with RoHS environmental criterion.

Item	Contents	Unit	Note
LCD Type	TFT	-	
LCD Panel Grade	INNOLUX	-	
Display color	16.7M		
Viewing Direction	12	O'Clock	
Gray scale inversion direction	6	O'Clock	
Operating temperature	-20~+70	°C	
Storage temperature	-30~+80	°C	
Module size	Refer to outline drawing	mm	
Active Area(W×H)	95.04X53.86	mm	
Number of Dots	480×272	dots	
Controller	ILI6480B	-	
Power Supply Voltage	3.3	V	
Outline Dimensions	Refer to outline drawing	-	
Backlight	10-LEDs (white)	pcs	
Weight	---	g	
Interface	RGB-24Bit (HV mode)	-	

4. Outline Drawing

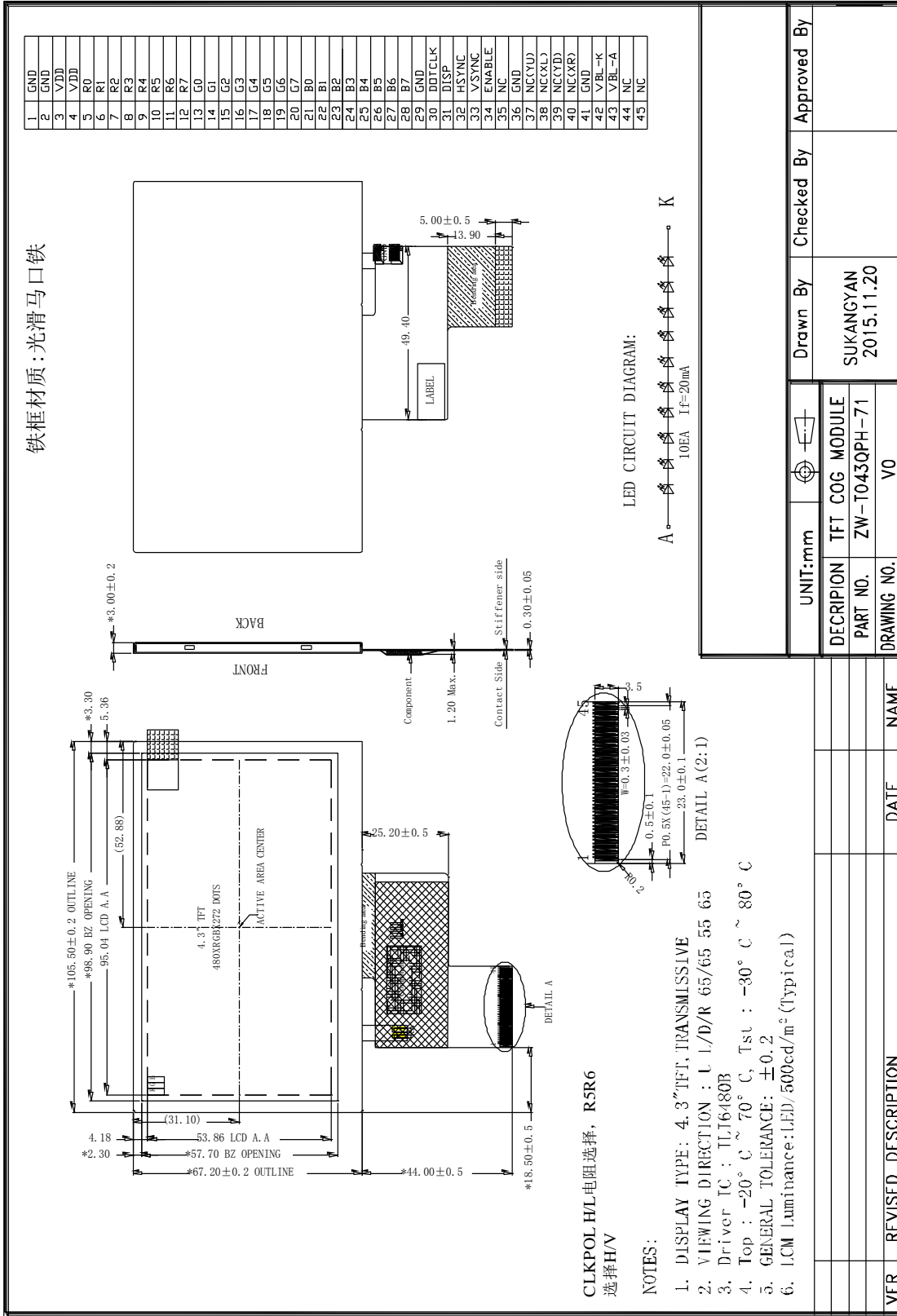

5. Absolute Maximum Ratings(Ta=25°C)

5.1 Electrical Absolute Maximum Ratings.(Vss=0V ,Ta=25°C)

Item	Symbol	Min.	Max.	Unit	Note
Power Supply Voltage	V _{CC}	-0.3	3.6	V	1
Logic Signal Input /Output Voltage	V _{I/OVCC}	-0.3	V _{CC} +0.5	V	
Power Supply Voltage for LCD	V _{op}	-	-	V	

Notes:

1 Please be sure users are grounded when handing LCD Module.

5.2 Environmental Absolute Maximum Ratings.

Item	Storage		Operating		Note
	MIN.	MAX.	MIN.	MAX.	
Ambient Temperature	-30°C	80°C	-20°C	70°C	1,2
Humidity	-	-	-	-	3

1. The response time will become lower when operated at low temperature.

2. Background color changes slightly depending on ambient temperature.

The phenomenon is reversible.

3. Ta<=40°C:85%RH MAX.

Ta>=40°C:Absolute humidity must be lower than the humidity of 85%RH at 40°C.

6. Electrical Specifications and Instruction Code

6.1 Electrical characteristics(V_{SS}=0V ,T_a=25°C)

Parameter	Symbol	Condition	Min	Typ	Max	Unit	Note
Power supply	V _{CC}	T _a =25°C	3.0	3.3	3.6	V	
Input voltage	'H'	V _{IH}	V _{CC} =3.3V	0.8V _{CC}	-	V _{CC}	V
	'L'	V _{IL}	V _{CC} =3.3V	0	-	0.2V _{CC}	V
Current Consumption	I _{CC1}	Normal mode	-	20	30	mA	
	I _{CC2}	Sleep mode	-	0.05	0.1	mA	
Clock Frequency	f _{CLK}	-	-	9	15	MHz	

6.2 LED backlight specification(VSS=0V ,Ta=25°C)

Item	Symbol	Condition	Min	Typ	Max	Unit	Note
Supply voltage	Vf	If=20mA	-	30.0	-	V	
Uniformity	Δ Bp	If=20mA	80			%	
Luminance for LCD	Lv	If=20mA	-	500		Cd/m2	
Life Time	time	If=20mA		20000		hours	1

Note:

1: The "LED Life time" is defined as the module brightness decrease to 50% original brightness at T=25°C and I_{LED} =20mA. The LED Life time could be decreased if operating I_{LED} is larger than 20mA

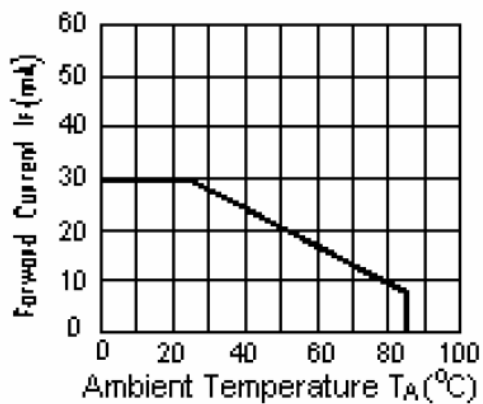

I_{LED} VS TEMP

6.3 Interface timing

6.3.1 Power On Sequence

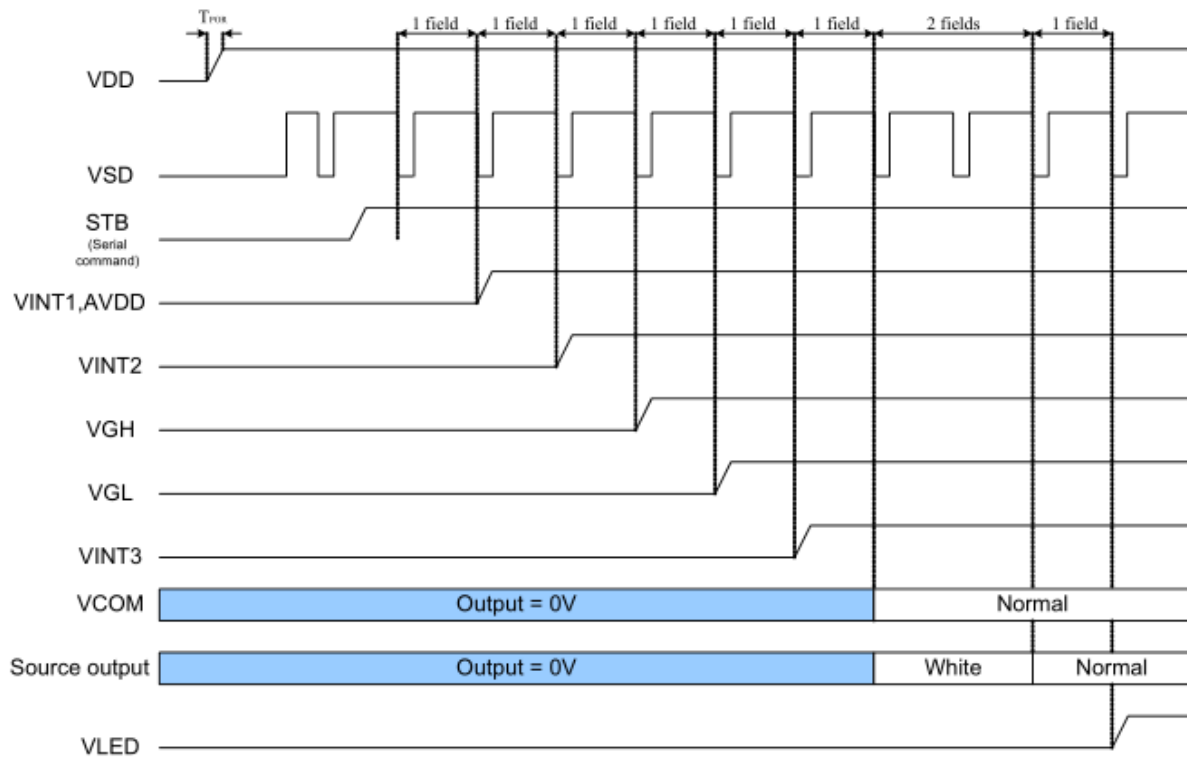

6.3.2 Power Off Sequence

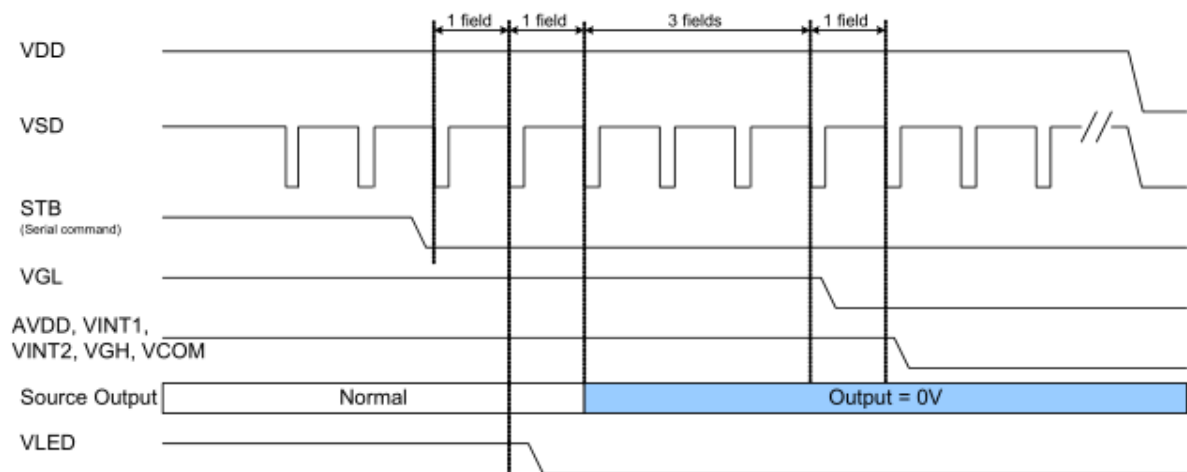

6.3.3 Input signal characteristics

Parameters	Symbol	Min.	Typ.	Max.	Unit	Conditions
System operation timing						
VDD power source slew time	TPOR	-	-	20	ms	From 0V to 99% VDD
GRB pulse width	tRSTW	10	50	-	us	R=10Kohm, C=1uF
Input Output timing						
DCLK clock time	Tclk	33.3	-	-	ns	DCLK=30MHz
Clock rising time	Trck	9	-	-	ns	
Clock falling time	Tfck	9	-	-	ns	
HSD width	Thwh	1	-	-	DCLK	
HSD period time	Th	55	60	65	us	
HSD setup time	Thst	12	-	-	ns	
HSD hold time	Thhd	12	-	-	ns	
VSD width	Tvwh	1	-	-	Th	
VSD setup time	Tvst	12	-	-	ns	
VSD hold time	Tvhd	12	-	-	ns	
Data setup time	Tdsu	12	-	-	ns	
Data hold time	Tdhd	12	-	-	ns	
DE setup time	Tdesu	12	-	-	ns	
DE hold time	Tdehd	12	-	-	ns	
Source output setting time	Tst	-	-	TBD	us	10% to 90% CL=60pF, RL=2Kohm
Gate output setting time	Tgst	-	500	1000	ns	10% to 90%, CL=60pF
VCOM output setting time	Tcst	-	-	TBD	us	10% to 90%, CL=40nF, RL=50ohm
Time from VSD to 1st line data input	Tvs	3	8	31	Th	HV mode By HDL[4:0] setting

6.3.4 Timing Chart

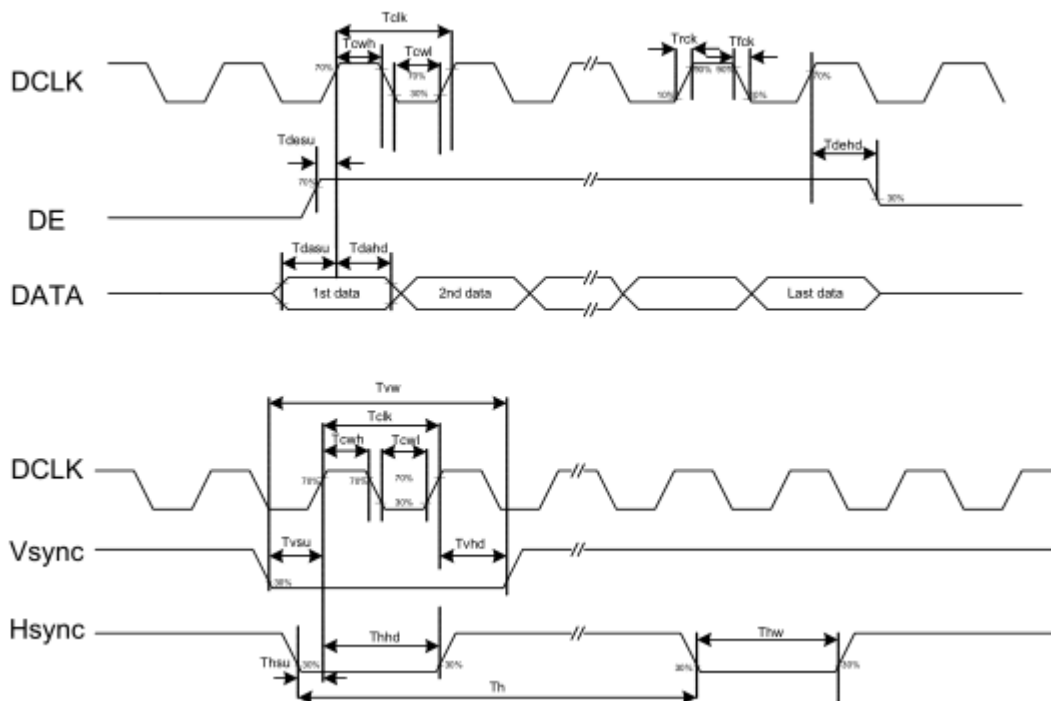

Clock and Data Input Waveforms

Vertical input timing

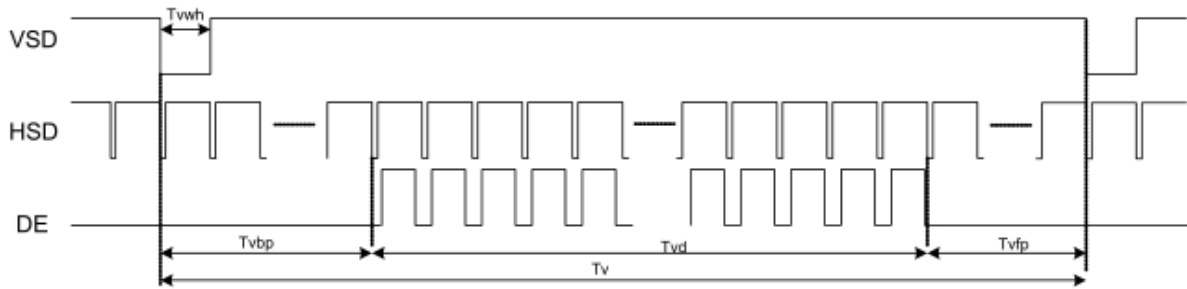

Serial 8-bit RGB Mode Data format

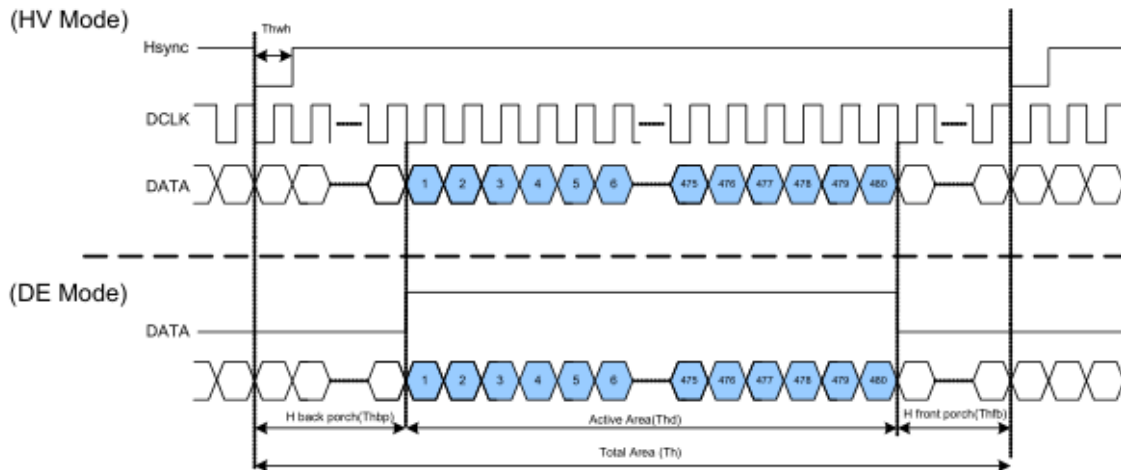

Parameters	Symbol	Min.	Typ.	Max.	Unit	Conditions
DCLK frequency	Fclk	24	27	30	MHz	
DCLK cycle time	Tclk	83	110	200	ns	
DCLK pulse duty	Tcwh	40	50	60	%	
Time from HSD to source output	Thso	-	13	-	DCLK	
Time from HSD to gate output	Thgo	-	27	-	DCLK	
Time from HSD to gate output off	Thgz	-	3	-	DCLK	
Time from HSD to VCOM	Thvc	-	12	-	DCLK	

Parallel RGB Mode Data format

(HV Mode)

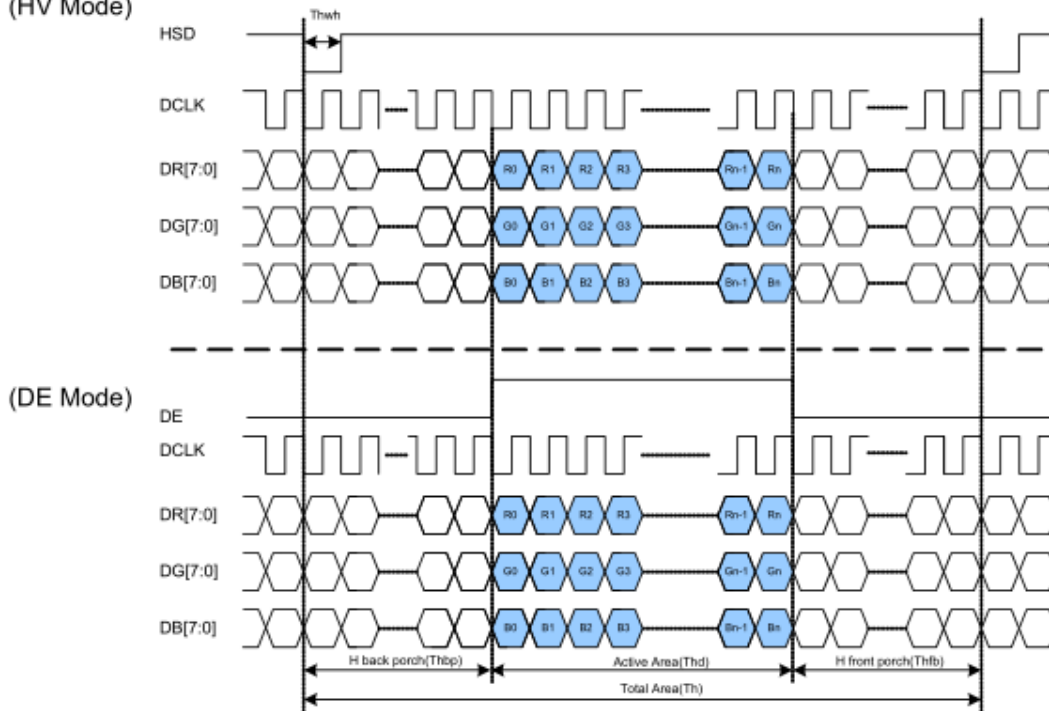

Parallel RGB input timign table

Parameter	Symbol	Value			Unit
		Min.	Typ.	Max.	
DCLK frequency	fclk	5	9	12	MHz
VSD period time	T_v	277	288	400	H
VSD display area	T_{vd}	272			H
VSD back porch	T_{vb}	3	8	31	H
VSD front porch	T_{vfp}	2	8	93	H
HSD period time	T_h	520	525	800	DCLK
HSD display area	T_{hd}	480			DCLK
HSD back porch	T_{hbp}	36	40	255	DCLK
HSD front porch	T_{hfp}	4	5	65	DCLK

6.4 Interface signals

Pin No.	Symbol	I/O	Function
1~2	GND	P	Ground.
3~4	VDD	P	Power supply
5-12	R0~R7	I	Red data bus
13-20	G0~G7	I	Green data bus
21-28	B0~B7	I	Blue data bus
29	GND		Ground.
30	DCLK	I	Data clock
31	DISP	I	Standby mode select pin
32	HSYNC	I	Line SYNC signal
33	VSYNC	I	Frame SYNC signal
34	ENABLE	I	Data enable pin
35	NC	-	No connection.
36	GND	P	Ground.
37	YU	O	Touch Panel Control pin(NC)
38	XL	O	
39	YD	O	
40	XR	O	
41	GND	P	Ground.
42	VBL-K	I	LED back light(Cathode)
43	VBL-A	I	LED back light(Anode)
44	NC	-	No connection.
45	NC	-	No connection.

7. Optical Characteristics

Item	Symbol	Condition	Min.	Typ.	Max.	Unit	Note
------	--------	-----------	------	------	------	------	------

Brightness	Bp	$\theta=0^\circ$	-	500	-	Cd/m ²	1
Uniformity	ΔBp	$\Phi=0^\circ$	80	-	-	%	1,2
Viewing Angle	3:00	Cr \geq 10	-	65	-	Deg	3
	6:00		-	55	-		
	9:00		-	65	-		
	12:00		-	65	-		
Contrast Ratio	Cr	$\theta=0^\circ$ $\Phi=0^\circ$	350	500	-	-	4
Response Time	T _r		-	10	-	ms	5
	T _f		-	10	-	ms	
Color of CIE Coordinate	W	x	$\theta=0^\circ$ $\Phi=0^\circ$	0.28	-	-	1,6
		y		0.33	-	-	
	R	x		0.51	-	-	
		y		0.34	-	-	
	G	x		0.31	-	-	
		y		0.56	-	-	
	B	x		0.15	-	-	
		y		0.14	-	-	
NTSC Ratio	S	50	60	-	%		

Note: The parameter is slightly changed by temperature, driving voltage and material

Note 1: The data are measured after LEDs are turned on for 5 minutes. LCM displays full white. The brightness is the average value of 9 measured spots. Measurement equipment PR-705 (Φ 8mm)

Measuring condition:

- Measuring surroundings: Dark room.
- Measuring temperature: Ta=25°C.
- Adjust operating voltage to get optimum contrast at the center of the display.

Measured value at the center point of LCD panel after more than 5 minutes while backlight turning on.

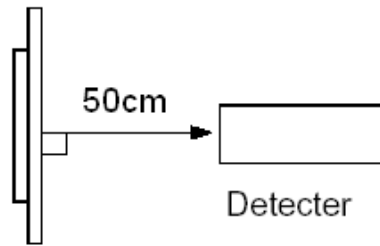

Note 2: The luminance uniformity is calculated by using following formula.

$$\Delta B_p = B_p (\text{Min.}) / B_p (\text{Max.}) \times 100 (\%)$$

$B_p (\text{Max.})$ = Maximum brightness in 9 measured spots

$B_p (\text{Min.})$ = Minimum brightness in 9 measured spots.

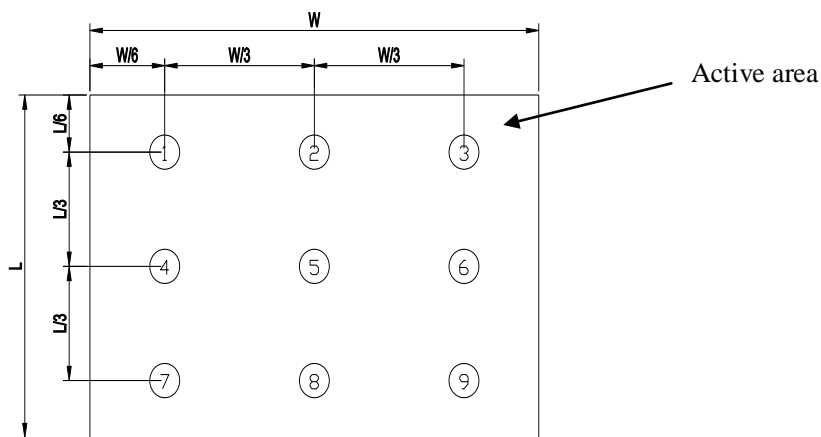

Note 3: The definition of viewing angle:

Refer to the graph below marked by θ and ϕ

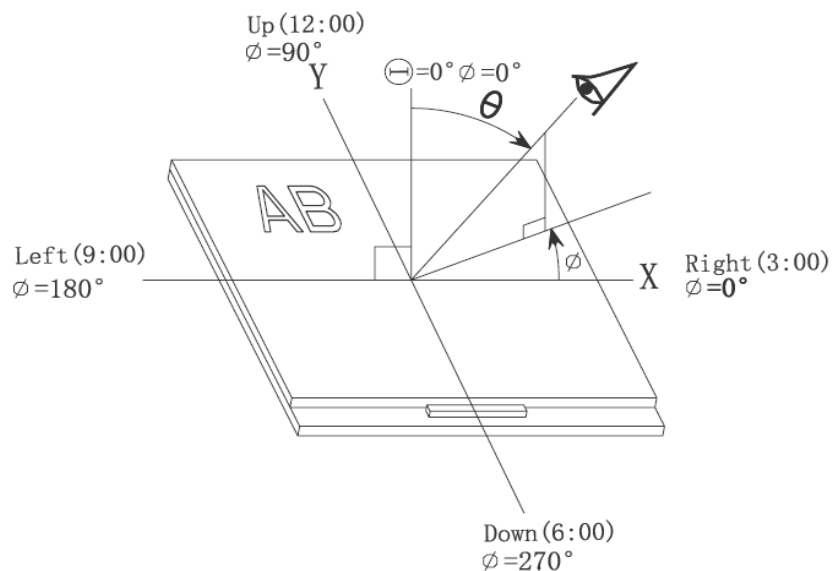

Note 4: Definition of contrast ratio.(Test LCD using DMS501)

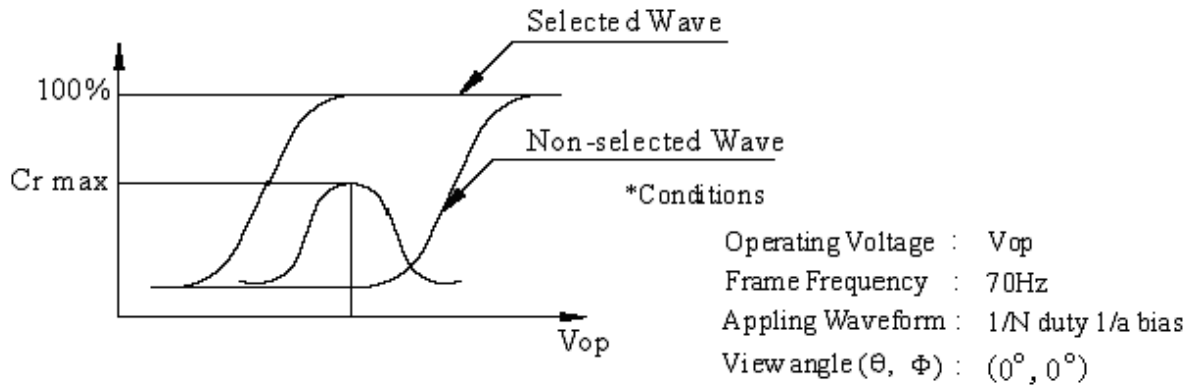

$$\text{Contrast ratio}(Cr) = \frac{\text{Brightness of selected dots}}{\text{Brightness of non-selected dots}}$$

Note 5: Definition of Response time. (Test LCD using DMS501):

The output signals of photo detector are measured when the input signals are changed from “black” to “white”(falling time) and from “white” to “black”(rising time), respectively. The response time is defined as the time interval between the 10% and 90% of amplitudes. Refer to figure as below.

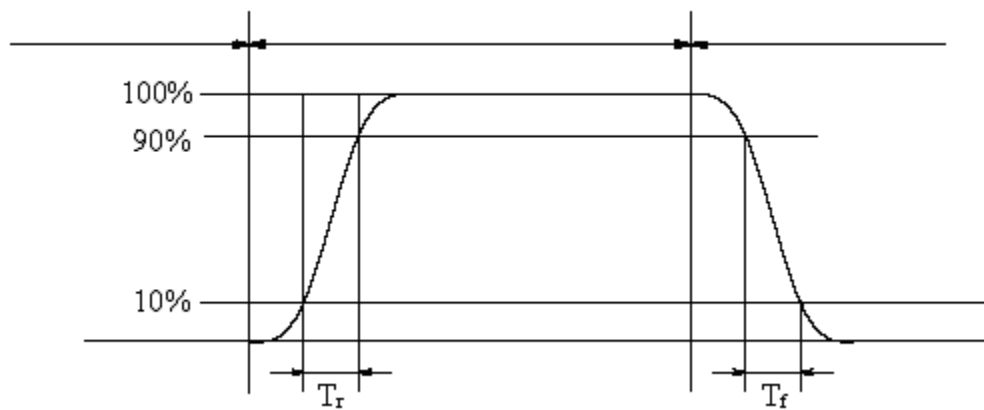

The definition of response time

Note 6: Definition of Color of CIE Coordinate and NTSC Ratio.

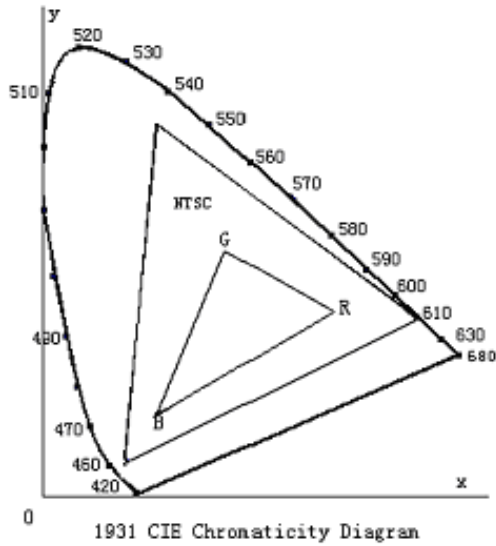

Color gamut:

$$S = \frac{\text{area of RGB triangle}}{\text{area of NTSC triangle}} \times 100\%$$

Note 7: Definition of cross talk.

Cross talk ratio(%)= | pattern A Brightness-pattern B Brightness | / pattern A Brightness*100

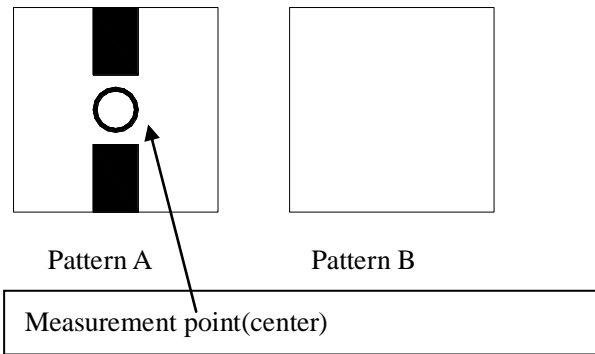

Electric volume value=3F+/-3Hex

8. Reliability Test Items and Criteria

No	Test Item	Test condition	Criterion
1	High Temperature Storage	80°C±2°C 96H Restore 2H at 25°C Power off	1. After testing, cosmetic and electrical defects should not happen. 2. Total current consumption should not be more than twice of initial value.
2	Low Temperature Storage	-30°C±2°C 96H Restore 2H at 25°C Power off	
3	High Temperature Operation	70°C±2°C 96H Restore 2H at 25°C Power on	
4	Low Temperature Operation	-20°C±2°C 96H Restore 4H at 25°C Power on	

5	High Temperature/Humidity Operation	60°C±2°C 90%RH 96H Power on	
6	Temperature Cycle	-30°C ————— 80°C 30min 5min 30min after 5 cycle, Restore 2H at 25°C Power off	
7	Vibration Test	10Hz~150Hz, 100m/s ² , 120min	Not allowed cosmetic and electrical defects.
8	Shock Test	Half- sine wave, 300m/s ² , 11ms	

Note: Operation: Supply 2.8V for logic system.

The inspection terms after reliability test, as below

ITEM	Inspection
Contrast	CR>50%
IDD	IDD<200%
Brightness	Brightness>60%
Color Tone	Color Tone+/-0,05

9. Precautions for Use of LCD Modules

9.1 Handling Precautions

9.1.1 The display panel is made of glass. Do not subject it to a mechanical shock by dropping it from a high place, etc.

9.1.2 If the display panel is damaged and the liquid crystal substance inside it leaks out, be sure not to get any in your mouth, if the substance comes into contact with your skin or clothes, promptly wash it off using soap and water.

9.1.3 Do not apply excessive force to the display surface or the adjoining areas since this may cause the color tone to vary.

9.1.4 The polarizer covering the display surface of the LCD module is soft and easily scratched. Handle this polarizer carefully.

9.1.5 If the display surface is contaminated, breathe on the surface and gently wipe it with a soft dry cloth. If still not completely clear, moisten cloth with one of the following solvents:

- Isopropyl alcohol
- Ethyl alcohol

Solvents other than those mentioned above may damage the polarizer. Especially, do not use the following:

- Water
- Ketone
- Aromatic solvents

9.1.6 Do not attempt to disassemble the LCD Module.

9.1.7 If the logic circuit power is off, do not apply the input signals.

9.1.8 To prevent destruction of the elements by static electricity, be careful to maintain an optimum work environment.

- a. Be sure to ground the body when handling the LCD Modules.
- b. Tools required for assembly, such as soldering irons, must be properly ground.
- c. To reduce the amount of static electricity generated, do not conduct assembly and other work under dry conditions.
- d. The LCD Module is coated with a film to protect the display surface. Be care when peeling off this protective film since static electricity may be generated.

9.2 Storage precautions

9.2.1 When storing the LCD modules, avoid exposure to direct sunlight or to the light of fluorescent lamps.

9.2.2 The LCD modules should be stored under the storage temperature range. If the LCD modules will be stored for a long time, the recommend condition is:

Temperature : $0^{\circ}\text{C} \sim 40^{\circ}\text{C}$

Relatively humidity: $\leq 80\%$

9.2.3 The LCD modules should be stored in the room without acid, alkali and harmful gas.

9.3 The LCD modules should be no falling and violent shocking during transportation, and also should avoid excessive press, water, damp and sunshine.

ZW-T043QPH-71 包装方式示意图

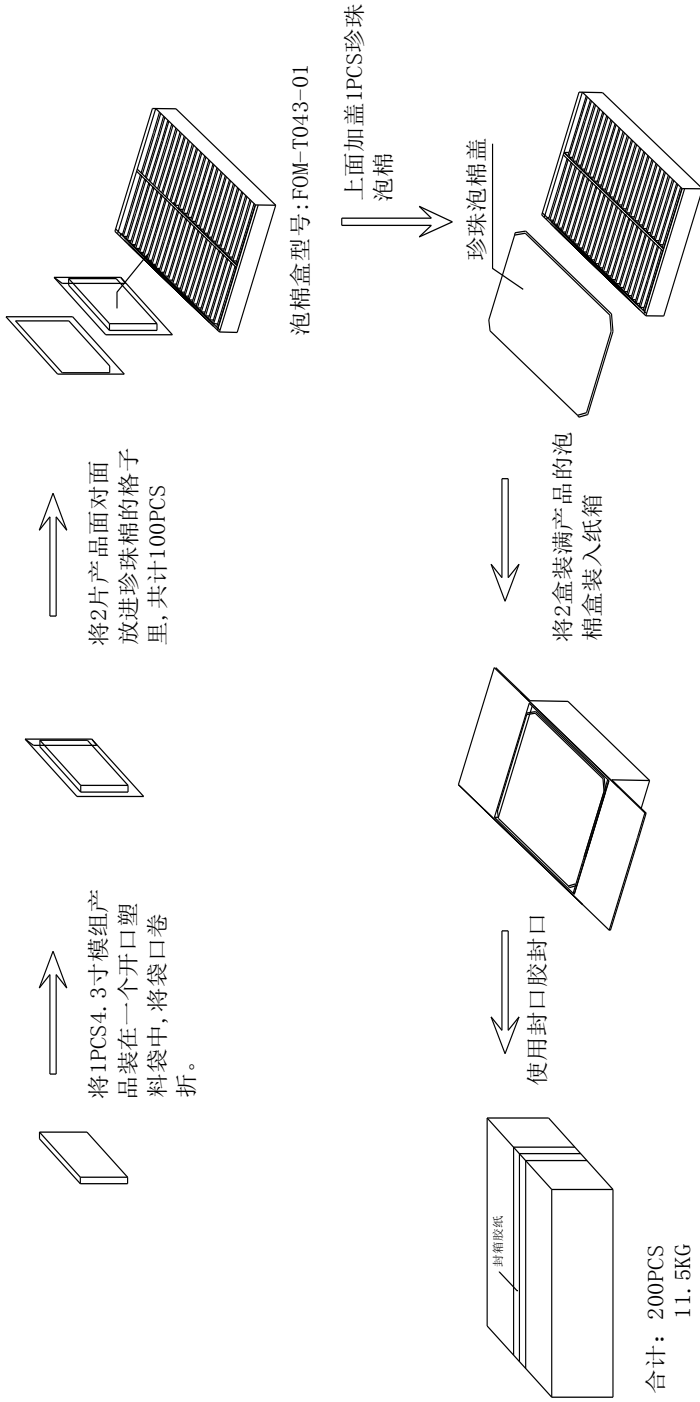

DLC DISPLAY COMPANY LIMITED		Drawn By	Checked By	Approved By
		Wuliyan		
UNIT:mm		2016.02.20		
VER	REVISED	DESCRIPTION	DATE	NAME